



All you see and hear is water.

tel 705.739.7878 | toll free 888.211.3548 | fax 705.739.7826 | 33 Alliance Blvd, Unit 6, Barrie, ON L4M 5K2 Canada | sales@arbrux.com

SUBMERSIBLE MIXERS



Intertek
FILE# 3179195

1/2, 1, 1.5 & 2 HP
Submersible Mixers

Congratulations on choosing the Arbrux Limited Submersible Mixer. We at Arbrux Limited appreciate your decision for choosing our leading ice management equipment. The following is a manual regarding the installation, usage, care and storage of your Submersible Mixer. Please store this manual in an easily accessible location. DO NOT DESTROY.

General Information

The following is provided to inform persons of potential injury hazards inherent with this product.

IMPORTANT SAFETY INSTRUCTIONS

- Under no circumstances should anyone enter the body of water when the Submersible Mixer is plugged in and/or in operation. It is NEVER recommended to enter water when any type of electrical equipment is in use. Also, the rotating propeller could result in serious injury. Turn off power and lock out before installing or servicing.
- Before attempting installation, service or maintenance to the Submersible Mixer in any body of water a coast guard approved flotation device must be worn.
- Always use a Ground Fault Protected circuit to power your Submersible Mixer. The unit must be grounded.
Failure to connect to a proper ground fault protected circuit could result in injury or death. Ground Fault Circuit interrupters must be tested upon installation and monthly thereafter.
- Attempting to install or service the Submersible Mixer from an unstable work platform could result in injury or death. Installation and/or service work must be done from a stable work platform to avoid the possibility of capsizing.
- Control Panels must be installed by a qualified electrician.
- Do not operate the Submersible Mixer out of water.
- 3 phase submersible mixers require a startup test to ensure correct rotation. If rotating in the opposite direction damage to the unit may occur.
- Arbrux Limited recommends that precautions be taken around open water and thin ice. Please install appropriate signage, lights, fencing or other safety notices to inform the general public of potential danger. Alternate safety measures may be required by law in your area.

When inherent overheating protection is provided: USE WITH APPROVED MOTOR CONTROL THAT MATCHES MOTOR INPUT IN FULL LOAD AMPERES.

UTILISER UN DÉMARREUR APPROUVÉ CONVENANT AU COURANT À PLEINE CHARGE DU MOTEUR.

Units supplied with SJOOW/SJTOW power cables are intended for household use, other applications require SOOW/STOW.

Les unités fournies avec les cordons d'alimentation de SJOOW/SJTOW sont voulues pour l'usage de ménage, les autres applications exigent SOOW/STOW.

Immediately inspect the shipment upon arrival. Any external evidence of loss or damage must be noted on the freight bill or express receipt, and signed by the carrier's agent. Failure to adequately describe such external evidence of loss or damage may result in the carrier refusing to honour a damage claim. The form required to file such a claim will be supplied by the carrier. *If an order has a short shipment, you must notify Customer Service within 5 days of receipt along with appropriate proof of short shipment. Otherwise shipment will be considered accepted as delivered.*

Components

Standard Submersible Mixers are packed with

- Power unit with selected power cord.
- Stainless steel S hooks (2)
- Rubber Grommets (2)
- Chain Shackle (1)
- Stainless Mounting Clamp (1)
- Tyrap (1)
- Mooring Rope (2x6 meters)

Installation, Operation & Maintenance

The Submersible Mixer is completely assembled.

Remove from shipping carton, remove foam packaging block from motor and install Stainless Steel S Hooks into the provided grommets (See fig 1). They can be installed and used in a Sling Mount formation (see fig 2), a Chain Mount formation (see Fig 1) or a Horizontal Mount (see fig 4)

DO NOT TURN THE UNIT ON UNTIL THE MOTOR IS SUBMERGED IN THE WATER.

The Franklin Submersible motor is water-cooled and water-lubricated. Consequently, it must not be allowed to bury itself in sand or mud. If this occurs, serious motor damage will result and warranty will be voided. Adequate depth for the Submersible Mixer to run would be 3 -5 feet. (Ensure the motor is clear of the bottom by one foot.)

In any installation ensure that the power cord cannot become entangled in the propeller. Use supplementary tyrap if necessary. Ensure that the Submersible Mixer is mounted sufficiently clear of obstructions.

Mounting Depth: For sling and chain mounting

An initial depth (propeller to surface) of five feet is suggested (ensure motor is clear of the bottom by one foot). To obtain maximum effect in any one location, experiment by increasing or decreasing the mounting depth one foot at a time and observe the effect.

Avoid dropping the unit, especially on a hard concrete surface. Damage to the thrust bearing assembly is not covered under warranty.

Horizontal Bracket Mounting

The mixer can be mounted on its side using the provided stainless steel clamp. Insert one Stainless Steel S Hook into the rubber grommet in as in the chain and sling mount. The other Stainless Steel S Hook clamped to the Motor bottom with the Stainless Steel Clamp. (see Fig. 4)

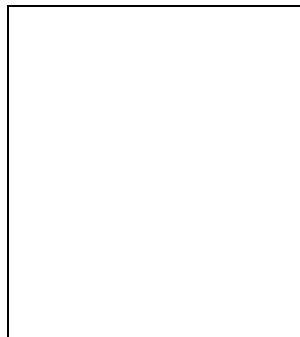

**FIGURE FOUR(4)
Horizontal Mount**

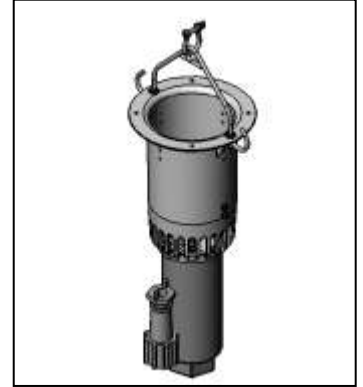

**FIGURE ONE(1)
Single Chain Mount**

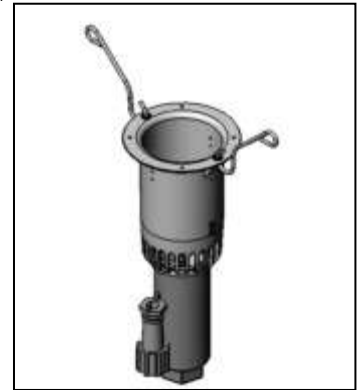

**FIGURE TWO(2)
Rope Mount**



**FIGURE THREE(3)
Optional Float**

Supplementary Instructions for Submersible Mixer with optional 42" Flotation Assembly

Mooring

Mooring rope included is appropriate for this installation. In some applications additional mooring points may be required. A sufficient length of rope should be used to allow the float to rise and fall with changes in water level. If major water level changes are expected, a small weight fixed part way down each rope will accommodate the line slack during low water. In smaller ponds, the ropes may be tied off to opposite sides, or as is commonly done in larger areas, anchored using concrete blocks or similar. The maximum distance between anchors should give the mooring line a scope of approx 3:1. (ie. In 10 feet of water, the anchors would be placed 50-60 feet apart.) Take care when placing the unit in position so that the power cord falls directly to the bottom. (Do not use power cord as a "mooring line").

Winter De-Icing or mixing and Grommet Installation

Insert the two (2) rubber grommets into the two (2) adjacent holes along the top edge of the drive structure. Angle the grommet as in fig 5. Press grommet firmly through the hole in the lip of the drive structure as in fig 6. Check to make sure that the grommet is seated snugly on both the top and bottom side of the drive structure lip as in fig 7.



FIGURE FIVE (5)



FIGURE SIX (6)

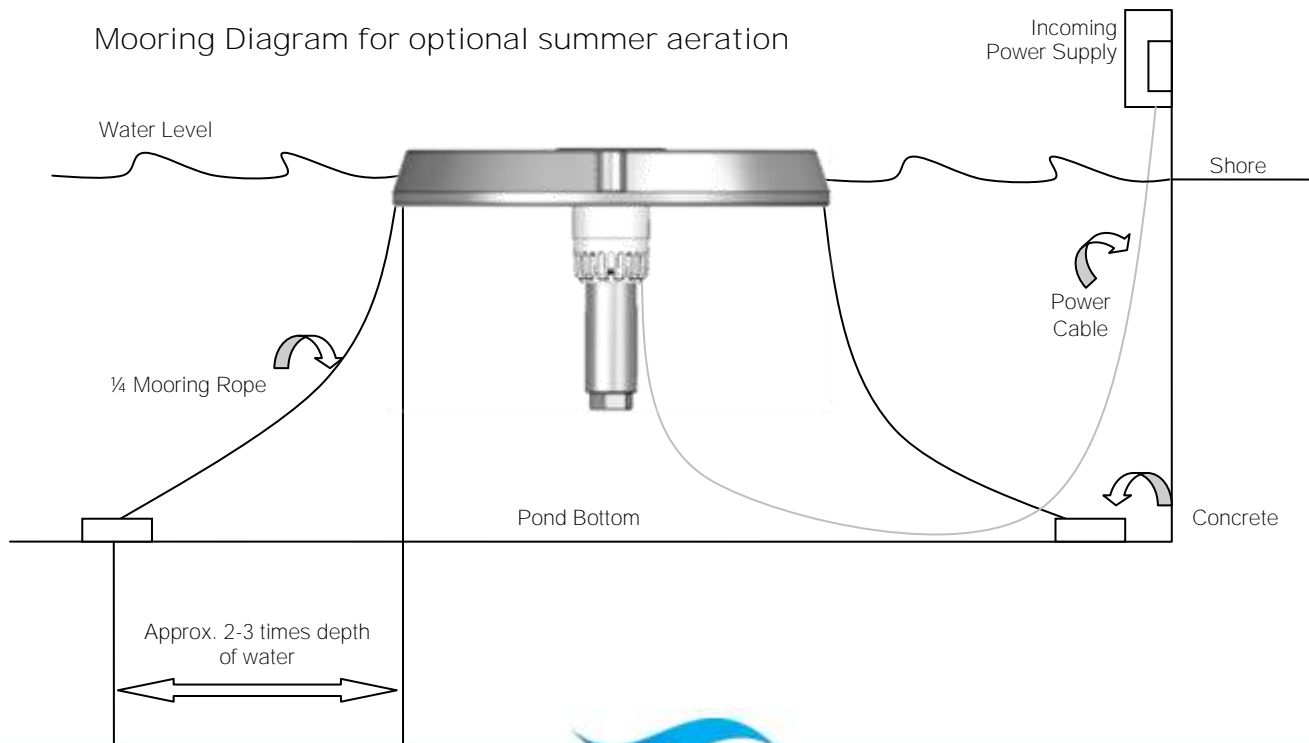

FIGURE SEVEN (7)

Assemble the S hooks in the "sling mount" configuration as per the standard Submersible Mixer instructions (fig 2). Using additional rope tie from each S hook to float ensuring that the Submersible Mixer is below the surface of the water. (fig 3). Be sure that the Submersible Mixer is not resting on the bottom of the body of water as motor failure can occur.

Summer Aeration

Remove the S hooks from the drive structure (fig 1 reversed). Place the unit into the molded contour in the surface of the float (mooring Figure). Provide additional strain relief for the power cord on the flotation assembly as may be appropriate for this installation.



Time Clock Programming

Electrical Control Panel Warranty (Control panel equipped models)

All electrical panel & onshore components have a one year warranty should they fail due to defects in materials or workmanship.

Control Panel Installation (Control panel equipped models)

The electrical control panel must be installed in accordance with the installation instructions, in compliance with all local and National Electrical Code requirements. This should be done by a licensed electrical contractor. Any alterations to or substitution for items in this system, unless allowed by the installation instructions, will void the CSA & UL Listing and will void the product warranty. It may also create a hazardous installation. Read the instructions thoroughly before starting the installation and follow them carefully throughout. The electrical drawings for your appropriate unit may be found in the control panel.

- Power supply to control panel must be sized for 3% or less voltage drop and match voltage and phase supplied on front of control panel. Test before energizing mixer and when mixer is running to ensure correct voltage
- Power supply terminates on top side of main breaker and ground connection to ground lug.
- Mount control panel in a shaded location to prevent excessive heat buildup
- Connect motor leads to appropriate terminals as per wiring diagram
- Connect optional light kit leads (if applicable) including remote photocell to appropriate terminals as per wiring diagram.
- Check motor overload setting matches panel nameplate rating
- Test main breaker ground fault trip and test monthly after
- Manually start mixer for a few seconds with timer manual control when it is in water (do not run dry) to check rotation (3 Phase Models). If rotating backwards spray pattern will be very small. Lockout power and then change motor lead phasing if necessary.
- Adjust time clock settings and set for automatic operation

Record the following

When the unit is running in the water under load

VOLTAGE	AMPERAGE
L1-L2 _____	L1 _____
L1-L3 _____	L2 _____
L2-L3 _____	L3 _____

Voltage and current imbalance should not exceed 5%. Voltage should be within 3% of nameplate rating.

Time Clock Programming

1. **TO SET "ON" and "OFF" TIMES:** Hold trippers against edge of CLOCK-DIAL, pointing to time (AM or PM) when ON and OFF operations are desired, tighten tripper screws firmly. For additional tripper pairs on CLOCK-DIAL order 154T1978A.
2. **TO SET TIME-OF-DAY:** Pull CLOCK-DIAL outward. Turn in either direction and align the exact time-of-day on the CLOCK-DIAL (the time now, when switch is being put into operation) to the pointer. **DO NOT MOVE THE POINTER**

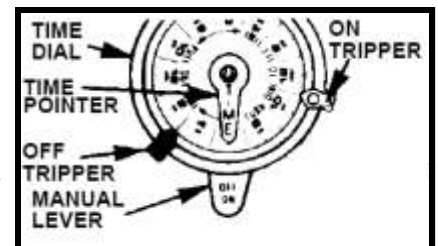

OPERATING INSTRUCTIONS

- **TO OPERATE SWITCH MANUALLY:** Move MANUAL LEVER below CLOCK-DIAL left or right as indicated by arrows. This will not effect next operation.
- **IN CASE OF POWER FAILURE** reset CLOCK-DIAL to proper time-of-day. See programming instructions.

Electrical Connections

All electrical connections shall be wired per local electrical codes. Determine the voltage of the unit 120 or 240V Single phase, 208,230,460 or 575V 3 phase. Ground fault protection is strongly suggested on any electrical device. Ground fault devices are not to be confused with or used as a circuit breaker or switch.

Motor Prefix	H.P	Volts	Maximum S.F Amps	Watts	Line to Line Resistance	Circuit Breaker Amp Size Standard	Fuse Amp Size Time Delay
214504	0.5	120	12A	1000	1.0-1.3	30	15
214505	0.5	240	6A	1000	4.2-4.5	15	8
234501	0.5	208	3.4A	1000	6.6-8.4	8	4
234511	0.5	230	2.9A	1000	9.5-10.9	6	4
234521	0.5	460	1.4A	1000	38.4-44.1	3	2
214508	1	240	9.8A	1500	2.2-2.7 M 10-1-12.3 S	25	25
234503	1	208	5.4A	1500	3.8-4.5	15	6
234513	1	230	4.7A	1500	4.9-5.6	10	6
234523	1	460	2.4A	1500	19.9-23.0	5	3
224301	2	240	13.2A	2100	M1.8-2.3 S5.8-7.2	25	15
234305	2	208	9.3A	2150	1.8-2.4	20	11
234315	2	230	8.1A	2150	2.3-3.0	20	10
234325	2	460	4.1A	2150	9.2-12.0	15	5

Note: Each Submersible Mixer is tested under operating conditions at the factory before packaging and shipment to verify operational characteristics at specific voltages.

Submersible Mixer Cable Runs							
Horsepower	Volts	Phase	14 Gauge	12 Gauge	10 Gauge	8 Gauge	6 Gauge
0.5	115	1	30	45	75	105	180
	240	1	120	180			
	208	3	180				
	230	3	180				
	460	3	180				
1	240	1	75	120	180		
	230	3	165	180			
	208	3	120	180			
	460	3	180				
2	240	1	45	75	120	180	
	230	3	90	150	180		
	208	3	60	105	180		
	460	3	180				

Note: Lengths shown are in meters. Cable size must be maintained from electrical panel to the fountain. Confirm with your local electrical code to insure cable sizes

Insulating & Winding Resistance Values

CONDITION OF MOTOR AND LEADS	OHM VALUE	MEGOHM VALUE
A used motor which can be reinstalled	10,000,000 (or more)	10
MOTOR IN WATER. OHM readings are for drop cable plus motor.		
A motor in the water in reasonably good condition	50,000- 2,000,000	0.5-2.0
A motor which may have been damaged by lightning or with damaged leads. Do not pull unit for this reason.	20,000- 500,000	0.02-0.5
A motor which definitely has been damaged or with a damaged cable. The unit should be pulled and repairs made to the cable/motor replaced. The motor will not fail for this reason alone, but it will probably not operate for long.	10,000- 20,000	0.01-0.02
A motor which has failed or with completely destroyed cable insulation. The unit must be pulled and the cable repaired/motor replaced.	less than 10,000	0.0-0.1
Insulation resistance does not vary with rating. Motors of all HP, voltage and phase rating have the same value of insulation resistance		

Important

Disassembly of the motor by anyone other than an authorized service centre or by the factory will void the warranty. There are no user serviceable parts in the motor.

The Submersible Mixer uses a super stainless submersible motor. These motors are filled with water therefore being water-cooled and the bearings are water-lubricated. For this reason in the winter months it is recommended that you store your Submersible Mixer in an upright position. Do not expose to temperature below 2°C and avoid exposure to temperatures over 49°C. It is recommended that the unit be removed from freezing conditions unless the unit is being utilized as a Submersible Mixer for the winter months.

Maintenance

The Submersible Mixer is virtually maintenance Free. We recommend that you remove the unit from the water periodically to visually inspect and clean any debris and build up on the motor and drive structure assembly. Be sure to check the propeller/impeller for wear. **DO NOT TAMPER WITH OR DISASSEMBLE THE MOTOR. SUCH TAMPERING WILL BE EVIDENT AND WILL VOID THE WARRANTY.**

Troubleshooting Tips

Motor will not run.	<ol style="list-style-type: none"> 1. Disconnect switch is off 2. Fuse is blown/breaker tripped (if applicable) 3. Overload tripped 4. Incorrect or no voltage 5. Motor winding open, shorted or grounded. 6. Low voltage 7. Pump Stuck or Binding 	<ol style="list-style-type: none"> 1. Place on "ON" position 2. Replace with proper size fuse. 3. Reset overload 4. Determine why voltage not available - broken wires, blown fuses, or disconnect switch off. If voltage is incorrect (ref. 120V Service and 230V Pump), customer must purchase proper voltage pump, or change power supply voltage to match pump. 5. Pull pump and replace motor or complete unit. 6. Check with Power Company. Install heavier wiring if wire size is too small. See wiring instructions. 7. Pump may be bound from debris. It may be necessary to pull pump and flush out the inside to free it up.
GFCI trips.	<ol style="list-style-type: none"> 1. Problem with electrical service 2. Water contamination to wire 3. Bad Breaker 4. Control Box/Motor Problems 	<ol style="list-style-type: none"> 1. Have a certified electrician diagnose the problem and contact Arbrux Limited for further instructions.
Motor runs hot and overload kicks off.	<ol style="list-style-type: none"> 1. Motor is wired incorrectly. 2. Voltage is too low. 	<ol style="list-style-type: none"> 1. Refer to motor I.D. label for instructions on wiring. 2. Check with Power Company. Install heavier wiring if wire size is too small. See wiring instructions.
Motor runs but no water is delivered.	<ol style="list-style-type: none"> 1. Intake area may be plugged. 2. Propeller/Impeller make be damaged 	<ol style="list-style-type: none"> 1. Clean intake screen. 2. Repair Pump
Little or no water delivered.	<ol style="list-style-type: none"> 1. Shorted run winding in motor. 2. Low voltage. 3. Intake screen plugged. 4. Pump parts worn. 	<ol style="list-style-type: none"> 1. Replace motor or complete pump. 2. Contact Power Company for corrective action. Install heavier wiring if too small. 3. Pull pump and clean screen. 4. Replace pump end or complete unit.

End of Submersible Mixer Instructions

2 Year Limited Warranty

This warranty is the only warranty that Arbrux Limited makes for your Submersible Mixer and it is in lieu of any other warranties, express or implied and any other obligation or liability whatever on the part of Arbrux Limited. Arbrux Limited warrants the Submersible Mixer should it fail due to defects in materials or workmanship for 24 months from date of shipment to the original purchaser. This warranty applies when given normal and proper usage as determined by the manufacturer upon examination and when owned by the original purchaser who has registered the warranty. In no event shall Arbrux Limited be held liable for any special or consequential damages.

Warranty Claim Procedure

Warranty determination will be made by our technical service department in accordance with the appropriate warranty policies. All warranties must be accompanied by a valid RMA number. This can be obtained by contacting Arbrux Limited Customer Service. A copy of original proof of purchase including serial number is required for all warranty returns. Please Mark RMA number prominently on outside of the box being shipped. Items returned for warranty will be FOB Arbrux Limited and should be returned in the original packaging to ensure minimal return shipping costs. If the original packaging is not retained and used by the customer, Arbrux Limited will supply replacement packaging (at a nominal charge) upon return of the equipment to the customer. Only complete assemblies including power cable will be considered for warranty repair. It is not necessary to return control box or float unless your electrician has determined the control box needs repair

Repair Returns

To avoid any delays in the repair of equipment in question, it's best to call the factory at 888-211-3548 to determine what portion or portions of the equipment in question should be returned. The Submersible Mixer is to be returned completely assembled. Do not disassemble any portion without prior authorization. A copy of original proof of purchase including serial number is required for all repair returns.

Shipping is FOB Arbrux Limited and all items should be returned in the original UPS approved packaging to ensure minimal shipping charges. If the original packaging is not retained and used by the customer, Arbrux Limited will supply replacement packaging (at a nominal charge) upon return of the equipment to the customer.

Upon the inspection of the returned equipment, whether in warranty or not, contact by Arbrux Limited to proceed with repair will be made to the owner or agent with an explanation of the repairs and charges if any. **NO REPAIRS WILL BE MADE UNLESS AUTHORIZED BY THE OWNER OR AGENT.** If Arbrux Limited is **unable to contact the owner/agent within 30 days after receipt of the equipment for repair, a "signature Required" notice will be forwarded to the owner/agent stating that disposal of the equipment will be made 30 days from the date of this notice.**

You may Contact:
Arbrux Limited
33 Alliance Blvd, Unit 6
Barrie, ON
L4M 5K2
1(888)211-3548

Customer Registration Copy

Owner Name: _____

Date Purchased: _____

Owner Address: _____

City: _____ Prov/State: _____

Model #: _____ Serial #: _____

Dealer Name: _____

Address: _____

City: _____ Prov/State: _____

Mail In form
Warranty Registration

Purchase Date: _____

Model #: _____ Serial #: _____

Owner Name: _____

Address: _____

City: _____ Prov/State: _____ PC/Zip: _____

Dealer Name: _____

Address: _____

City: _____ Prov/State: _____ PC/Zip: _____

SUBMERSIBLE MIXER PARTS LIST

TBD

